

Ersatzteilliste

Spare Parts List / Liste des pièces détachées / Lista di parti di ricambio

Antriebsaggregat AU

*AU drive unit
Groupe d'entraînement AU
Gruppo di comando AU*

Index / Indice 004

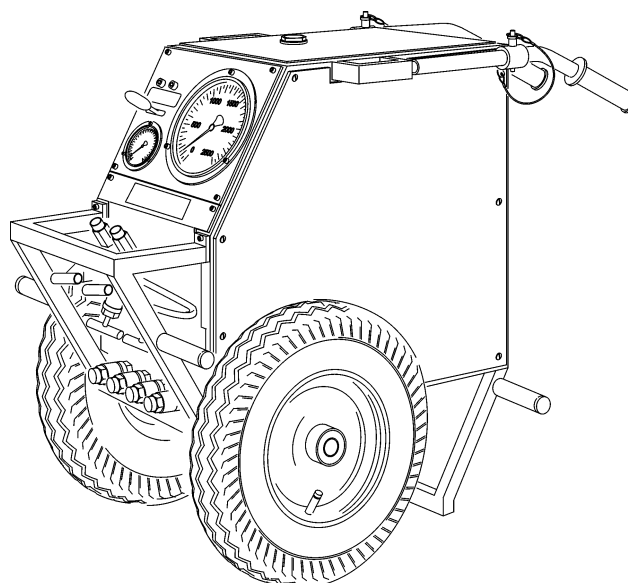

Verwendung der Ersatzteilliste

Die Ersatzteilliste ist keine Montage- oder Demontageanleitung. Diese Ersatzteilliste dient ausschliesslich zum einfachen und schnellen Finden von Ersatzteilen, die bei der untenstehenden Adresse bestellt werden können.

Sicherheitsvorschrift



Gefahr

Montieren oder demontieren von Baugruppen kann Risiken bergen, auf die in dieser Ersatzteilliste nicht hingewiesen wird.

Das Verwenden dieser Ersatzteilliste für Montage- oder Demontagezwecke ist strikte verboten. Für Montage- und Demontearbeiten sind ausschliesslich die entsprechenden Beschreibungen in der Betriebsanleitung zu befolgen.

Nichtbeachten dieser Vorschrift kann zu Verletzungen führen, die im schlimmsten Fall auch den Tod zur Folge haben könnten.

Bestellungen



Information

Um Falschlieferungen zu vermeiden sollten vor der Versendung die Angaben in der Bestellung auf Richtigkeit und Vollständigkeit (siehe unter Bestellangaben) überprüft werden.

Es ist auch darauf zu achten, dass die Lieferadresse vollständig angegeben ist.

Bestelladresse:

TYROLIT Hydrostress AG
Witzbergstrasse 18
CH-8330 Pfäffikon
Switzerland
Telefon +41 (0) 44 / 952 18 18
Telefax +41 (0) 44 / 952 18 18
e-mail: info@tyrolit.com
www.tyrolit.com

0 Ersatzteilliste

0.1 Bestellangaben

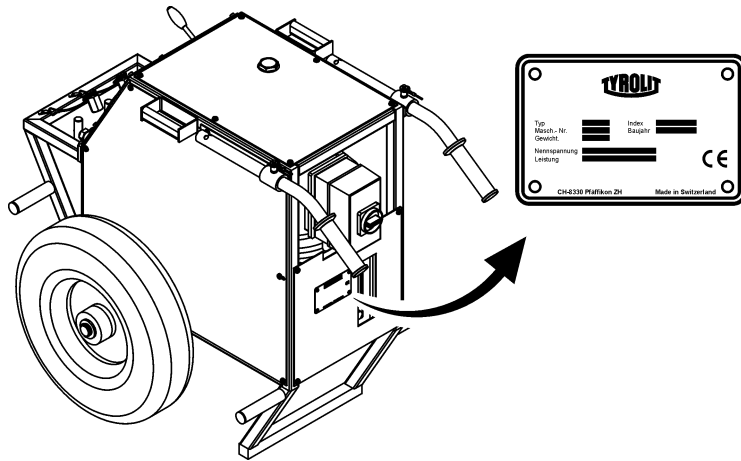

Bei Bestellungen von Ersatzteilen benötigen wir folgende Angaben:

- Maschinentyp gemäss Typenschild (z.B. AU)
- Maschinennummer gemäss Typenschild (z.B. 10977640)
- Maschinenindex gemäss Typenschild (z.B. 000)
- Ersatzteilnummer gemäss Ersatzteilliste (z.B. 10977530)

Für Bestellungen, Fragen und Informationen wenden Sie sich bitte an die zuständige Niederlassung.

How to use the spare parts list

The spare parts list is not intended as instructions for assembly or dismantling work. It is exclusively intended to help you to quickly and easily find spare parts, which can then be ordered at the address below.

Safety regulations



Danger

The assembling or dismantling of modules can involve risks which are not identified in this spare parts list.

The use of this spare parts list for assembly or dismantling purposes is strictly forbidden. For assembly or dismantling tasks it is essential to only follow the corresponding descriptions in the operating manual.

If this regulation is not heeded injuries may be incurred which in the worst case can also be fatal.

Ordering



Information

To avoid incorrect deliveries you should check the order details for correctness and completeness (see under ordering details) prior shipment.

You should ensure that the delivery address is given in full.

Order address:

TYROLIT Hydrostress AG

Witzbergstrasse 18

CH-8330 Pfäffikon

Switzerland

Tel. +41 (0) 44 / 952 18 18

Fax +41 (0) 44 / 952 18 18

e-mail: info@tyrolit.com

www.tyrolit.com

0 Spare Parts List

0.1 Ordering details

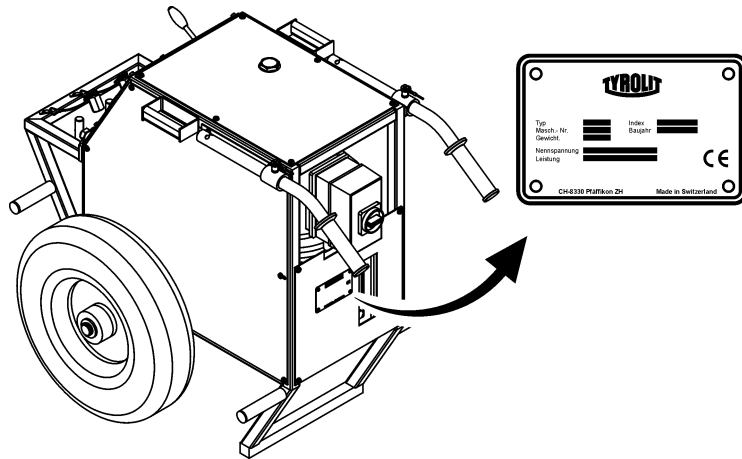

When spare parts are ordered we need the following details:

- Machine type according to nameplate (e.g. AU)
- Machine number according to nameplate (e.g. 10977640)
- Machine index according to nameplate (e.g. 000)
- Spare part number according to the spare parts list (e.g. 10977530)

For orders, questions and information please contact your responsible branch office.

Utilisation de la liste des pièces détachées

La liste des pièces détachées n'est pas une instruction de montage ou de démontage. Cette liste sert exclusivement à trouver simplement et rapidement les pièces détachées, qui peuvent être commandées à l'adresse mentionnée ci-dessous.

Prescription de sécurité



Danger

Le montage ou le démontage des modules peut présenter des risques dont il n'est pas fait mention dans cette liste des pièces détachées.

Il est strictement interdit d'employer cette liste des pièces détachées à des fins de montage ou de démontage. Pour les opérations de montage et de démontage, il faut exclusivement suivre les descriptions correspondantes dans le mode d'emploi.

Le non-respect de la présente prescription peut conduire à des blessures, pouvant même entraîner la mort.

Commandes



Information

Pour éviter des livraisons inappropriées, il est conseillé de vérifier avant l'expédition l'exactitude et l'exhaustivité des indications fournies dans la commande (voir Données de commande).

Il faut aussi veiller à bien indiquer l'adresse de livraison en entier.

Adresse de commande :

TYROLIT Hydrostress AG

Witzbergstrasse 18

CH-8330 Pfäffikon

Suisse

Téléphone +41 (0) 44 / 952 18 18

Télécopie +41 (0) 44 / 952 18 18

e-mail: info@tyrolit.com

www.tyrolit.com

0 Liste des pièces détachées

0.1 Données de commande

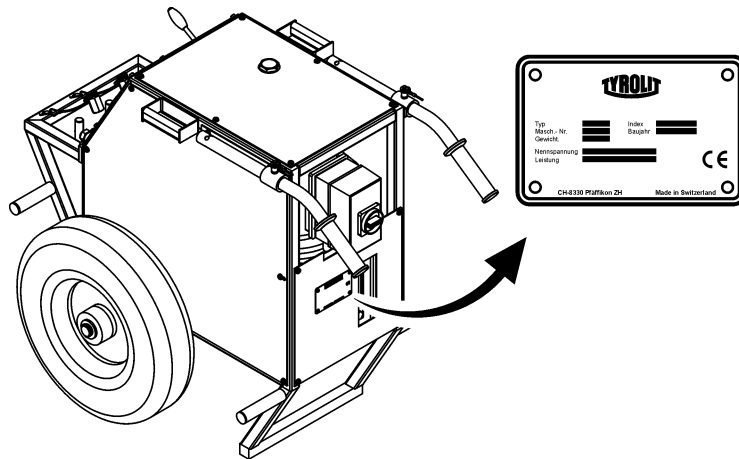

Lors de la commande de pièces détachées, nous avons besoin des données suivantes :

- Type de machine selon la plaque signalétique (p.ex. AU)
- Numéro de machine selon la plaque signalétique (p.ex. 10977640)
- Indice de machine selon la plaque signalétique (p.ex. 000)
- Numéro de pièce détachée selon la liste des pièces détachées (p.ex. 10977530)

Pour les commandes, questions et informations, vous êtes prié de vous adresser à la filiale compétente.

Uso della lista di parti di ricambio

La lista di parti di ricambio non è un manuale d'istruzioni per montaggio o smontaggio. Questa lista di parti di ricambio serve esclusivamente per trovare in modo semplice e rapido parti di ricambio che possono essere ordinate all'indirizzo riportato qui sotto.

Norme di sicurezza



Pericolo

Il montaggio o lo smontaggio di componenti della macchina può comportare pericoli che non sono indicati in questa lista di parti di ricambio.

E' assolutamente vietato servirsi di questa lista di parti di ricambio per scopo di montaggio o di smontaggio. Per operazioni di montaggio o smontaggio occorre seguire esclusivamente le relative istruzioni nel manuale per l'uso della macchina.

La mancata osservanza di queste norme può comportare lesioni, e nel caso peggiore anche la morte.

Ordinazioni



Informazione

Per evitare forniture incorrette, occorre verificare prima dell'invio dell'ordinazione se i dati indicati in essa sono corretti e completi (vedere la lista dei dati per l'ordinazione).

Occorre verificare anche se l'indirizzo per la consegna è esatto e completo.

Indirizzo per ordinazioni:

TYROLIT Hydrostress AG

Witzbergstrasse 18

CH-8330 Pfäffikon

Svizzera

Tel. +41 (0) 44 / 952 18 18

Fax +41 (0) 44 / 952 18 00

e-mail: info@tyrolit.com

www.tyrolit.com

0 Lista di parti di ricambio

0.1 Dati per l'ordinazione

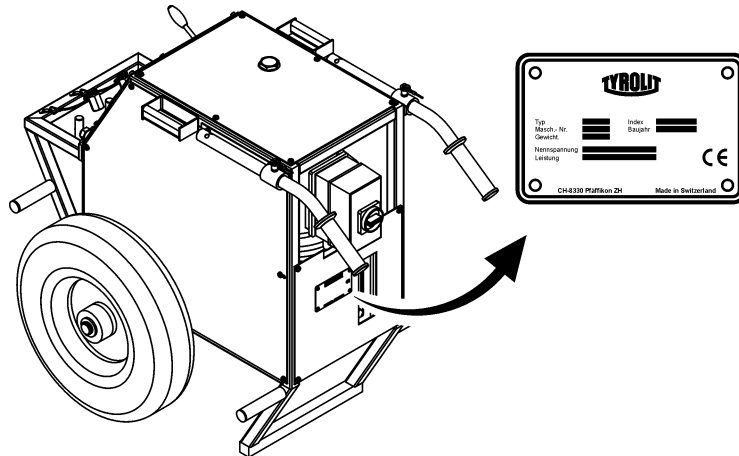

Per ordinazioni di parti di ricambio ci occorrono i dati seguenti:

- Tipo di macchina indicato sulla targhetta della macchina (per es. AU)
- Numero della macchina indicato sulla targhetta della macchina (per es. 10977640)
- Indice della macchina indicato sulla targhetta della macchina (per es. 000)
- Numero della parte di ricambio secondo la lista di parti di ricambio (per es. 10977530)

Per ordinazioni, domande o richieste d'informazioni Vi preghiamo di rivolgerVi all'agenzia competente.

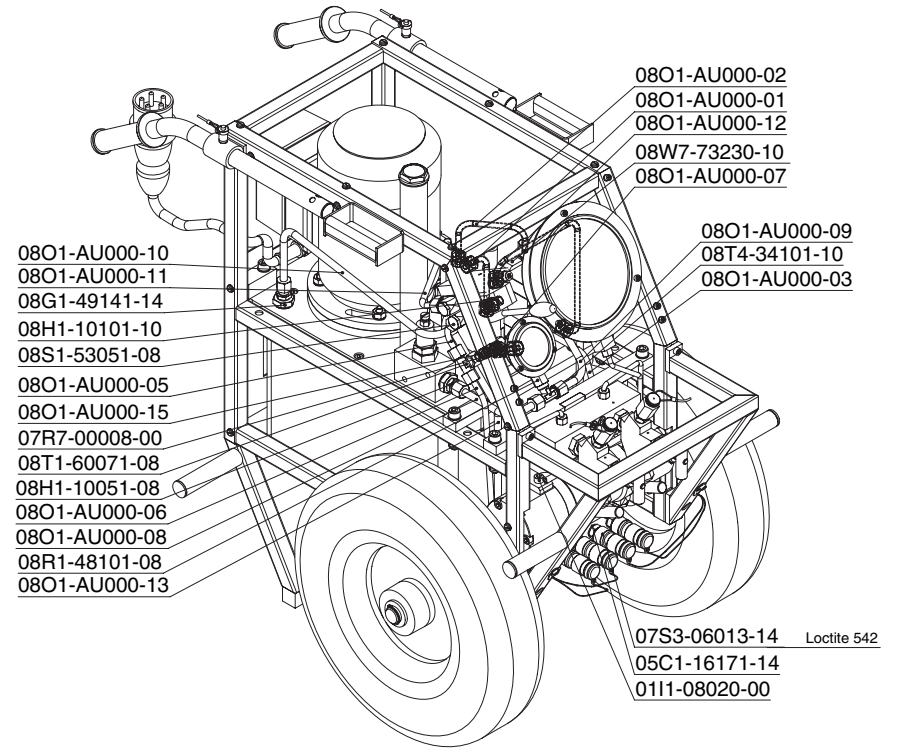
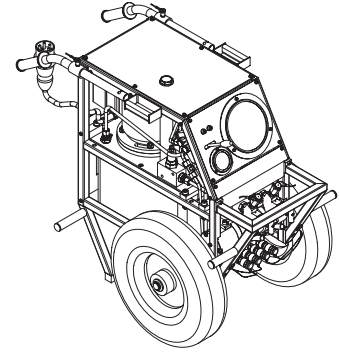
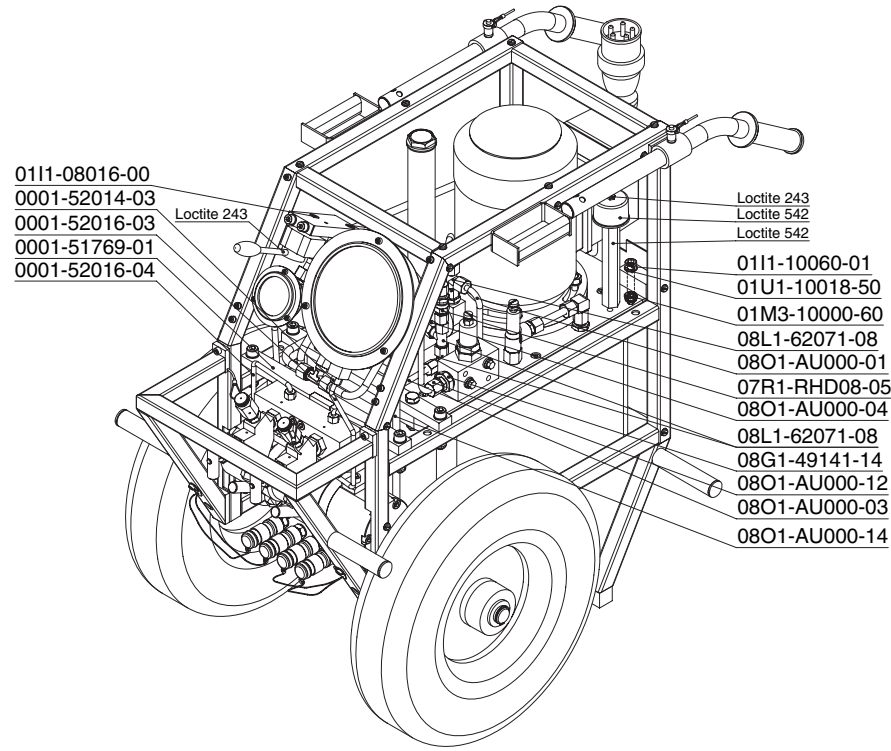

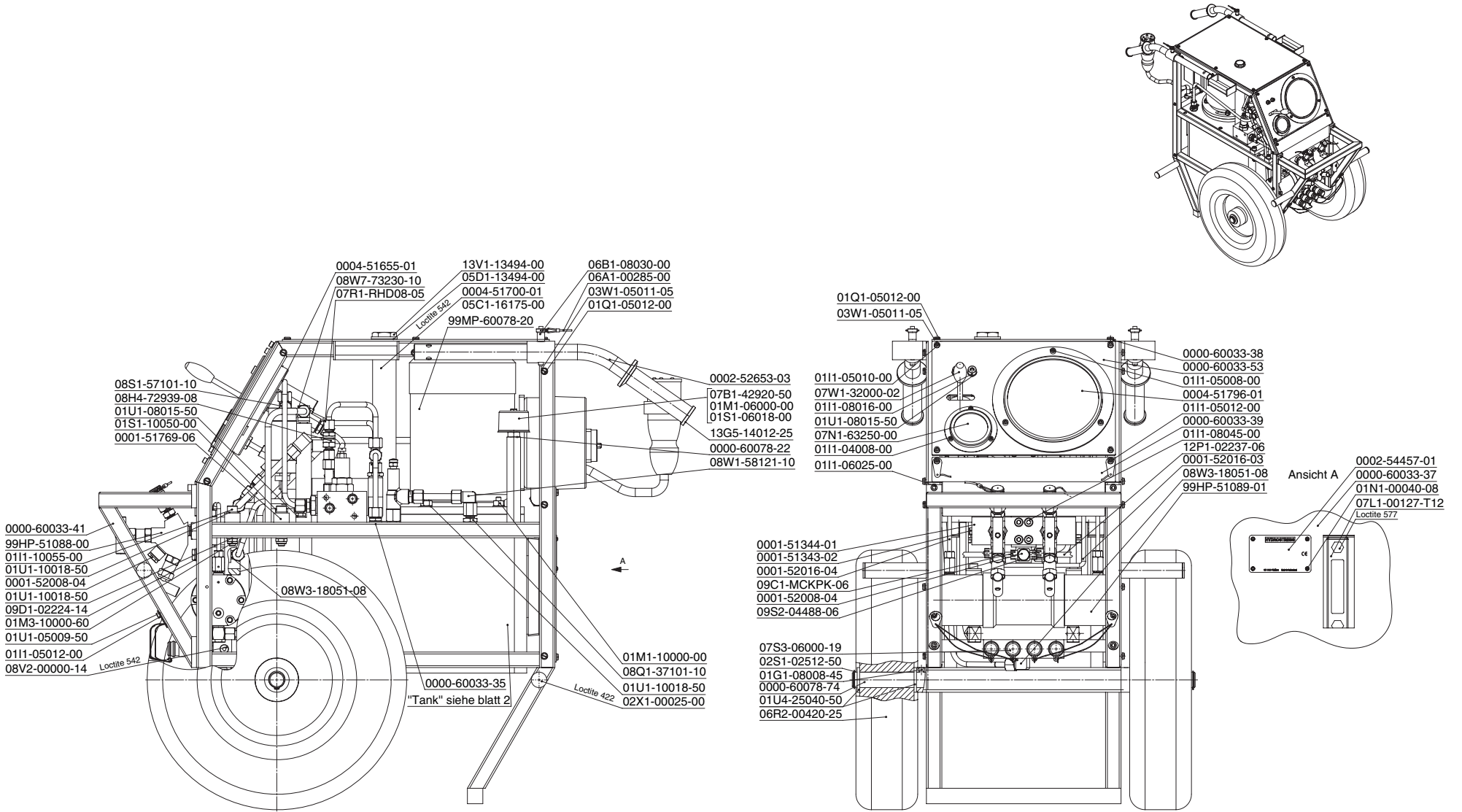

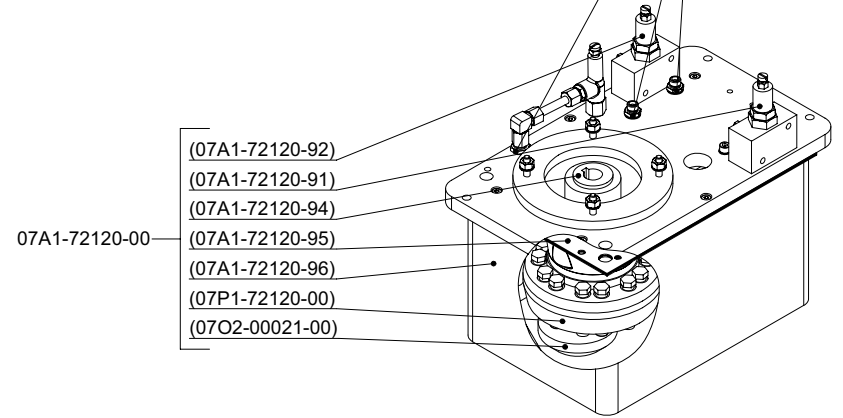
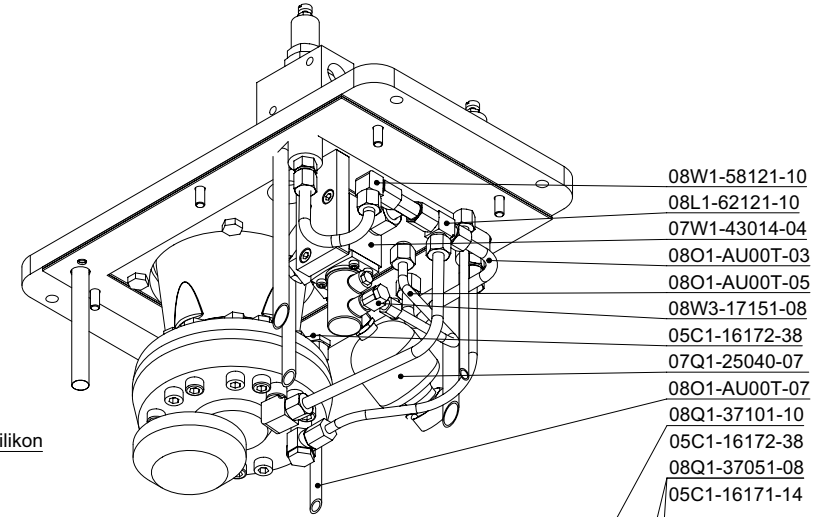
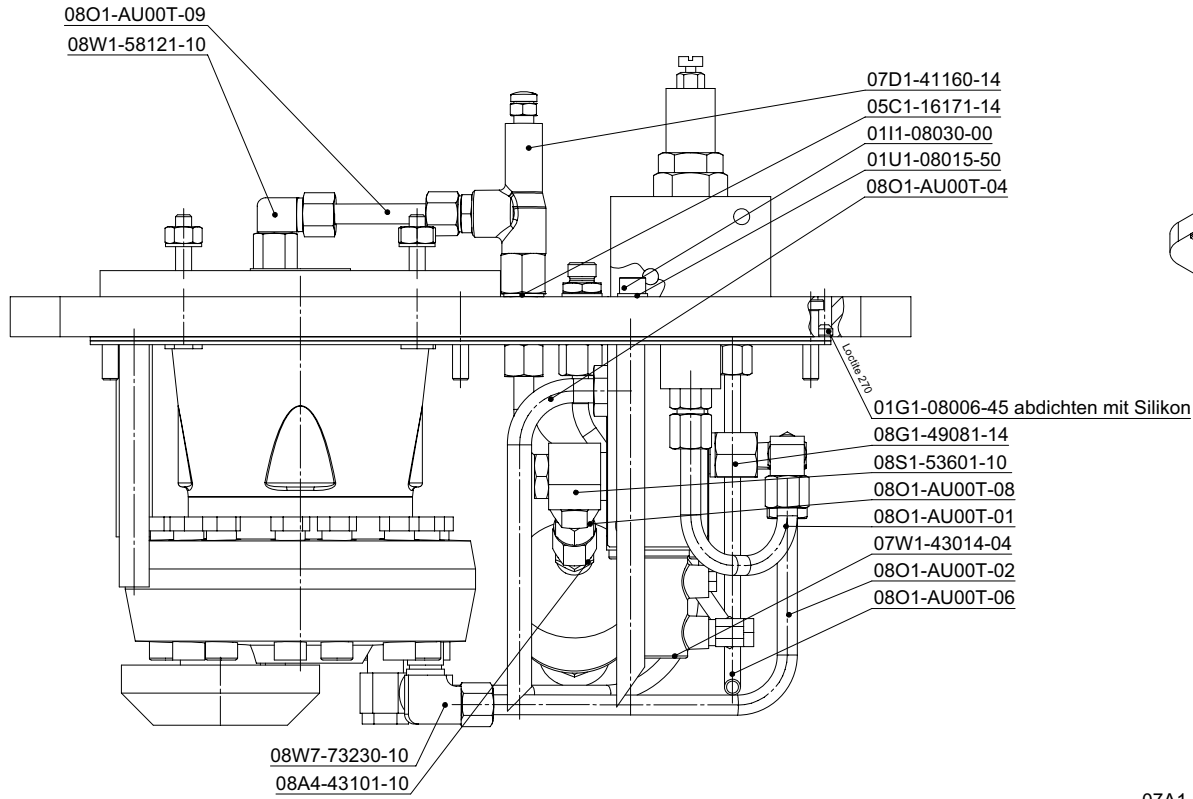

Zeichn. Nr.	Mat. Nr.	Deutsch	English	Français	Italiano	Stk.
MPEL-AU	975754	HD-Antrieb AU 400V/50 EU	High pressure pump	Groupe d'entrainement AU	Centralina AU	
99HP-51088-00	974041	HD-3-Weg-Hahn	High pressure 3-way-valve	Vanne HP 3 Voies	Rubinetto	2
99HP-51089-01	974042	Booster kompl.	High pressure booster	Booster complet	Booster kompl.	1
99HP-52394-00	974051	HD-Takter Danfoss	HP control unit	HD-Takter Danfoss	HD-Takter Danfoss	1
99MP-60078-20	980682	EI.-Motor m. Anbau	EI.-Motor with attachment	EI.-Motor mit Anbau	EI.-Motor mit Anbau	1
0000-60033-35	10981390	Chassis AU skyblue	Chassis AU skyblue	Châssis AU skyblue	Telaio AU skyblue	1
0000-60033-36	10981391	Seitenblech AU skyblue	Side plate AU skyblue	Chape latérale AU skyblue	Lamiera laterale AU skyblue	2
0000-60033-37	10981392	Frontblech AU skyblue	Front plate AU skyblue	Tôle frontale AU skyblue	Lamiera frontale AU skyblue	1
0000-60033-38	10981393	Deckblech AU skyblue	Cover plate AU skyblue	Tôle de recouvrement AU skyblue	Lamiera di copertura AU skyblue	1
0000-60033-39	10981394	Blende AU skyblue	Blind AU skyblue	Banedau AU skyblue	Blenda AU skyblue	1
0000-60033-41	10981395	Schutzbügel AU skyblue	Hoop-guard AU skyblue	Protection	Protezione	1
0000-60033-53	10981396	Schalttafel AU skyblue	Switchboard AU skyblue	Tableau de commande AU skyblue	Quadro di controllo AU skyblue	1
0000-60078-22	978281	Belüftungsrohr	Vent tube	Tube aeration	Mantice	1
0000-60078-74	978283	Achse AU-GR	Shaft AU-GR	Axe AU-GR	Albero AU-GR	1
0001-51343-02	970314	Verschl.schr. Booster	Locking screw booster	Bouchon de fermeture à vis booster	Tappo a vite booster	1
0001-51344-01	976234	Sammelblock 2A/AU/AR	Collector block 2A/AU/AR	Boitier de connexion 2A/A	Träger	1
0001-51769-01	970359	Booster-Träger AR/AU/4B	Booster support AR/AU/4B	Booster-Träger AR/AU/4B	Block	1
0001-51769-06	970360	Tankträger AR/AU	Tank holder AR/AU	Träger	Asta metal.serbatoio AR/AU	1
0001-52008-04	970446	Hohlschraube 2A/AR/AU/4B	Banjo bolt	Vis creuse 2A/AR/AU/4B	Vite cava mandrino 2A/AR/AU/4B	1
0001-52014-03	970450	HD-Leitungsverschr. 2A/AU	HD-pipe screwings 2A/AU	Raccord HP 2A/AU	Raccordo HP 2A/AU	5
0002-52016-03	971206	Manometerleitung AU/AR	Manometer pipe AU/AR	Tuyau manomètre AU/AR	Condotto manometro AU/AR	1
0002-52016-04	971207	Boosterleitung AR/AU	Booster pipe AR/AU	Conduite Booster AR/AU	Condotto booster AR/AU	2
0002-52653-03	979054	Griffrohr	Grip tube	Poignee	Maniglia	2
0002-54457-01	975923	TY-HS Typensch.100x60	HS-type plate 100x60	Plaque de fabrication HS 100x60	Targhetta del modello HS 100x60	1
0004-51655-01	971555	Ventilplatte klein Antr.	Valve plate small	Plaque	Piastra	2

MPEL-AU	975754	HD-Antrieb AU 400V/50 EU	High pressure pump	Groupe d'entrainement AU	Centralina AU	
Zeichn. Nr.	Mat. Nr.	Deutsch	English	Français	Italiano	Stk.
0004-51700-01	971556	Oeleinfüllstutzen AU/AR	Oil filler AU/AR	Raccord	Manicotto	1
01G1-08006-45	971634	Gewindestift M8x6	Slotted set screw M8x6	Vis sans tête M8x6	Vite senza testa M8x6	2
01G1-08008-45	971635	Gewindestift M8x 8	Slotted set screw M8x 8	Vis sans tête M8x 8	Vite senza testa M8x 8	2
0111-04008-00	971677	Inbus-Schraube M4x8	Allen head screw M4x8	Vis à six pans creux M4x8	Vite ad esagono cavo M4x8	3
0111-05010-00	971688	Inbus-Schraube M5x10	Allen head screw M5x10	Vis à six pans creux M5x10	Vite ad esagono cavoM5x10	4
0111-05012-00	971689	Inbus-Schraube M5x12	Allen head screw M5x12	Vis à six pans creux M5x12	Vite ad esagono cavo M5x12	4
0111-06025-00	971711	Inbus-Schraube M6x25	Allen head screw M6x25	Vis à six pans creux M6x25	Vite ad esagono cavo M6x25	4
0111-08016-00	971731	Inbus-Schraube M8x16	Allen head screw M8x16	Vis à six pans creux M8x16	Vite ad esagono cavo M8x16	6
0111-08020-00	979283	Inbus-Schraube M8x20	Allen head screw M8x20	Vis à six pans creux M8x20	Vite ad esagono cavo M8x20	2
0111-08030-00	971738	Inbus-Schraube M8x30	Allen head screw M8x30	Vis à six pans creux M8x30	Vite ad esagono cavo M8x30	2
0111-08045-00	971744	Inbus-Schraube M8x45	Allen head screw M8x45	Vis à six pans creux M8x45	Vite ad esagono cavo M8x45	4
0111-10055-00	971771	Inbus-Schraube M10x55	Allen head screw M10x55	Vis à six pans creux M10x55	Vite ad esagono cavo M10x55	4
0111-10060-00	971772	Inbus-Schraube M10x60	Allen head screw M10x60	Vis à six pans creux M10x60	Vite ad esagono cavo M10x60	2
0112-04010-00	10980343	Inb-Schr.nied.Kopf M4x10	Allen head screw M4x10	Vis à six pans creux bas M4x10	Vite ad esagono cavo a testa bassa	2
01M1-06000-00	979307	Mutter 6 kt. M6x0.8d	Nut hex. M6x0.8d	Ecrou 6 pans M6x0.8d	Dado M6x0.8d	1
01M3-10000-60	971862	Stop-Mutter M10 nied.Form	Stop-nut M10 thin head	Ecrou Nielstop M10	Dado d'arresto M10	8
01N1-00040-08	974830	Popniete d=4 l=13.9	Pop-riwet d=4 l=13.9	Rivet d=4 l=13.9	Chiodo d=4 l=13.9	4
01Q1-05012-00	971880	Pan-Head-Schr. M5x12	Panhead screw	Vis à tête plate M5x12	Vite M5x12	28
01S1-06018-00	971892	6kt-Schraube M6x18	Hexagonal screw M6x18	Vis à tête hexagonale M6x18	Vite a testa esagonale M6x18	1
01S1-10050-00	971909	6kt-Schraube M10x50	Hexagonal screw M10x50	Vis à tête hexagonale M10x50	Vite a testa esagonale M10x50	2
01U1-05009-50	971953	U-Scheibe M5	Washer M5	Rondelle M5	Rondella M5	4
01U1-05009-50	971953	U-Scheibe M5	Washer M5	Rondelle M5	Rondella M5	4
01U1-08015-50	979353	U-Scheibe M8	Washer M8	Rondelle M8	Rondella M8	4
01U1-10018-50	971958	U-Scheibe M10	Washer M10	Rondelle M10	Rondella M10	14
01U4-25040-50	971972	U-Scheibe Dm25x40x4	Washer Dm25x40x4	Rondelle Dm25x40x4	Rondella Dm25x40x4	4
MPEL-AU	975754	HD-Antrieb AU 400V/50 EU	High pressure pump	Groupe d'entrainement AU	Centralina AU	
Zeichn. Nr.	Mat. Nr.	Deutsch	English	Français	Italiano	Stk.
02S1-02512-50	971996	Seegerring Welle Dm 25	Seeger circlip-ring Dm 25	Anneau de retenue Seeger Dm 25	Anello tipo seeger Dm 25	2

6	02X1-00025-00	979400	Verschlussstopfen Dm25	Blanking plug Dm 25	Bouchon d'étanchéité Dm 25	Chiusura Dm 25	4
	03W1-05011-05	972105	Federscheibe gewellt M5	Spring disk, ribbed M5	Rondelle élastique M5	Rondella elastica ondulata M5	28
	05C1-16171-14	972186	Kupferdichtung G 1/4	Copper sealing G 1/4	Joint G 1/4	Guarnizione di rame G 1/4	9
	05C1-16172-38	972187	Kupferdichtung G 3/8	Copper sealing G 3/8	Joint G 3/8	Guarnizione di rame G 3/8	3
	05C1-16175-00	972189	Kupferdichtung G 1	Copper sealing G 1	Joint G 1	Guarnizione di rame G 1	1
	06A1-00285-00	972353	Befest.Kabel zu Ball-Lok	Fixing lever	Cable fixa./goupille poig	Cavo di fissaggio	6
	06B1-08030-00	972355	Schnelltrennbolzen 8x30	Quick separating pin 8x30	Goupille fixation poignee 8x30	Perno attacco rapido 8x30	2
	06R2-00420-25	977204	Luftrad 420/100/25	Wheel cpl. 420/100/25	Roue 420/100/25	Ruota 420/100/25	2
	07A1-72120-00	972494	Hydr.Aggregat R7.2-1.2 B	Hydr.Aggregate R7.2-1.2 B	Agrégat hydraulique R7.2-1.2 B	Aggregato idraulico R7.2-1.2 B	1
	07B1-42920-50	979649	Belüftungsfilter M18x1.5	Vent filter M18x1.5	Airfilter M18x1.5	Filtro dell'aria M18x1.5	1
	07D1-41160-14	972507	Druckbegr.ventil MVS 41 E	Pressure control valve MVS 41 E	Soupape de limitation MVS 41 E	Valvola di limitazione di pressione	1
	07L1-00127-T1	979661	2 Oelstand FSA 127-1.1/T/12	Oil lever FSA 127-1.1/T/12	Niveau d'huile FSA 127-1.1/T/12	Livello dell'olio FSA 127-1.1/T/12	1
	07N1-63250-00	972666	Manome. 250bar Tafeleinb.	Manometer 250bar Tafeleinb.	Manomètre 250bar Tafeleinb.	Manometro 250bar Tafeleinb.	1
	07Q1-25040-07	972757	Druckspeicher 250/40bar	Pressure vessel 250/40bar	Réservoir de pression 250/40 bar	Accumulatore di pressione 250/40 bar	1
	07R1-RHD08-05	972762	Rückschl.vent.Rohr 8 5bar	Back pressure valve 8	Clapet anti-retour 8 5bar	Valvola di ritorno 8 5bar	1
	07R7-00008-00	972773	Wechselventil Rohr 8	Distributing valve pipe 8	Soupape tube 8	Valvola tubo 8	1
	07S3-06000-19	972796	Staubkappe zu Nippel ND	Dust cap	Protecteur de raccord	Tappo racc.cont.martinetto	4
	07S3-06013-14	972798	Stecknippel Va A 2-WR013	Plug-in nipple Va A 2-WR013	Raccord mâle Va A 2-WR013	Raccordo innestabile Va A 2-WR013	4
	07W1-32000-02	972816	Steuerschieber SG 1 R-NE	Control valve SG 1 R-NE	Distributeur complet SG 1 R-NE	Valvola a cassetto SG 1 R-NE	1
	07W1-43014-04	972819	Steuerschieber SG 0 L-C	Control valve SG 1 R-NE	Distributeur complet SG 1 R-NE	Valvola a cassetto SG 1 R-NE	1
	08A4-43101-10	972842	Aufschr.vers. M14x1,5-10L	Tight. screw M14x1,5-10L	Vissage M14x1,5-10L	Avvitamento M14x1,5-10L	1
	08G1-49081-14	972869	Gew.red. G3/8 A-G1/4 I	Fitting G3/8 A-G1/4 I	Raccord G3/8 A-G1/4 I	Raccordo G3/8 A-G1/4 I	2
	08G1-49141-14	972872	Gew.red. G1/2 A-G1/4 I	Fitting G1/2 A-G1/4 I	Raccord G1/2 A-G1/4 I	Raccordo G1/2 A-G1/4 I	3
	08H1-10051-08	972876	Ger.Versch. 1/4-08L	Straight screw connection 1/4-08L	Vissage droit 1/4-08L	Avvitamento diritto 1/4-08L	2

MPEL-AU	975754	HD-Antrieb AU 400V/50 EU	High pressure pump	Groupe d'entrainement AU	Centralina AU	
Zeichn. Nr.	Mat. Nr.	Deutsch	English	Français	Italiano	Stk.
08H1-10101-10	972877	Ger.Versch. 1/4-10L	Straight screw connection	Vissage droit 1/4-10L	Avvitamento diritto 1/4-10L	5
08H4-72939-08	972890	Gerade Verb. Rohr 8L	Straight conn. pipe 8L	Tube 8L	Tubo 8L	1
08L1-62071-08	972905	L-Verschraubung Rohr 08 L	L-type connection 08L	Raccord a vis en L tube 08L	Raccordo "L" 08L	2
08L1-62121-10	972906	L-Versch. Rohr 10 L	L-type connection 10L	Raccord a vis en L tube 10L	Raccordo "L" 10L	1
08O1-AU000-01	10986160	Rohr AU Danfoss-Tank	Pipe AU Danfoss tank	Tube AU Danfoss réservoir	Tubo AU serbatoio Danfoss	1
08O1-AU000-02	10986161	Rohr Danfoss-Rückschlagventil	Pipe AU Back pressure valve	Tube AU soupape de non-retour	Tubo valvola di rimando	1
08O1-AU000-03	10986162	Rohr Rückl.-Hochdruckhahn	Pipe AU	Tube AU	Tubo	1
08O1-AU000-04	10986163	Rohr Steuerschieber-Tank	Pipe AU control valve tank	Tube AU distributeur réservoir	Tubo serbatoio valvola a cassetto	1
08O1-AU000-05	10986164	Rohr Steuerschieber-Wechselventil	Pipe AU	Tube AU	Tubo	1
08O1-AU000-06	10986165	Rohr Waltherk.-Steuerschieber	Pipe AU	Tube AU	Tubo	1
08O1-AU000-07	10986166	Rohr Wechselventil-Reduktion	Pipe AU	Tube AU	Tubo AU	1
08O1-AU000-08	10986167	Rohr DBV-T-Verschraubung	Pipe AU DBV T-conneiotn	Tube AU raccord T DBV	Tubo AU raccordo a T DBV	1
08O1-AU000-09	10986168	Rohr T-Verschraubung - 4/2Wegventil	Pipe AU	Tube AU	Tubo AU	1
08O1-AU000-10	10986169	Rohr 4/2 Wegeventil-Tank	Pipe AU	Tube AU	Tubo AU	1
08O1-AU000-11	10986170	Rohr Steuerschieber-Danfoss	Pipe AU control valve tank	Tube AU distributeur réservoir	Tubo serbatoio valvola a cassetto	1
08O1-AU000-12	10986171	Rohr AU DBV-Steuerschieber	Pipe AU control valve DBV	Tube AU distributeur DBV	Tubo valvola a cassetto DBV	1
08O1-AU000-13	10986172	Rohr AU Booster links	Booster pipe AU left	Tube Booster AU gauche	Tubo booster sinistro	1
08O1-AU000-14	10986173	Rohr AU Booster rechts	Booster pipe AU right	Tube booster AU droite	Tubo booster destro	1
08O1-AU000-15	10986174	Rohr AU Manometer-Rohr	Pipe AU manometer	Tube AU manomètre	Tubo manometro	1
08O1-AU00T-01	10986149	AU-Tank Steuerschieber-Arbeits DBV	Tank AU control valve DBV	Distributeur complet DBV	Valvola a cassetto DBV	1
08O1-AU00T-02	10986152	Tank Steuerschieber-Pumpe	Pipe AU control valve pump	Tube AU pompe distributeur	Tubo AU pompa valvola a cassetto	1
08O1-AU00T-03	10986153	Tank DBV-Steuerschieber	Tank AU control valve DBV	Réservoir AU distributeur DBV	Serbatoio AU valvola a cassetto DBV	1
08O1-AU00T-04	10986154	Tank Rücklauf Steuerschieber	Tank AU control valve DBV	Distributeur complet DBV	Valvola a cassetto DBV	1
08O1-AU00T-05	10986155	Tank Steuerschieber-Tackter	Tank AU control valve DBV	Distributeur complet DBV	Valvola a cassetto DBV	1
08O1-AU00T-06	10986156	Tank Rücklauf Rückschlagventil	Valve AU	Soupape AU	Valvola AU	1

MPEL-AU 975754 HD-Antrieb AU 400V/50 EU High pressure pump Groupe d'entrainement AU Centralina AU

Zeichn. Nr.	Mat. Nr.	Deutsch	English	Français	Italiano	Stk.
08O1-AU00T-07	10986157	Tank Rücklauf DBV	Tank return line DBV	Réservoir retour DBV	Serbatoio AU riflusso DBV	1
08O1-AU00T-08	10986158	Tank Verbindung Druckspeicher	Tank Verbindung Druckspeicher	Tank Verbindung Druckspeicher	Tank Verbindung Druckspeicher	1
08O1-AU00T-09	10986159	Tank DBV-Rücklaufverbindung	Tank DBV-Rücklaufverbindung	Tank DBV-Rücklaufverbindung	Tank DBV-Rücklaufverbindung	1
08Q1-37051-08	972941	Schottverschr. Rohr 08 L	Scr. bulkhead pipe 08 L	Raccord passe-cloison 08L	Raccordo tubo 08 L	2
08Q1-37101-10	972942	Schottverschr. Rohr 10 L	Scr. bulkhead pipe 10 L	Raccord passe-cloison 10L	Raccordo tubo 10L	1
08R1-48101-08	972949	Red.Einsatz Rohr 10-08 L	Red.insert pipe 10-08 L	Raccord tube 10-08L	Raccordo 10-08L	1
08S1-53051-08	972958	Schwenkverschr. 1/4-08 L	Swivelling fitting 1/4-08 L	Raccord à vis orientable 1/4-08 L	Collegamento a vite orientabile 1/4-08	3
08S1-53601-10	972962	Schwenkverschr. 3/8-10 S	Swivelling fitting 3/8-10 S	Raccord à vis orientable 3/8-10 S	Collegamento a vite orientabile 3/8-10	1
08T1-60071-08	972971	T-Verschr. Rohr 08 L	T-fitting pipe 08 L	Raccord en T Tube 08L	Raccordo a T Tubo 08L	1
08T3-32101-10	972974	T-Verschr. 1/4NPT-10L	T-fitting 1/4NPT-10L	Raccord en T 1/4NPT-10L	Raccord a T 1/4 NPT-10L	1
08T4-34101-10	972976	T-Verschr. Rohr 10 L	T-fitting pipe 10 L	Raccord en T Tube 10L	Raccordo a T Tubo 10L	1
08V2-00000-14	979747	Verschlussschr. 1/4-kon.	Locking screw 1/4 kon.	Bouchon de fermeture à vis 1/4 Kon	Tappo a vite 1/4 Kon	1
08W1-58121-10	972989	Winkelverschr. Rohr 10L	Angle connection Pipe 10L	Raccord à vis coudé tube 10L	Avvitamento angolare tubo 10L	2
08W3-17151-08	972995	Winkelverschr. 1/8NPT-8LL	Angle connection 1/8NPT-8LL	Raccord à vis coudé 1/8NPT-8LL	Avvitamento angolare 1/8NPT-8LL	1
08W3-18051-08	972996	Winkelverschr. 1/4NPT-08L	Angle connection 1/4NPT-08L	Raccord à vis coudé 1/4NPT-08L	Avvitamento angolare 1/4NPT-08L	2
08W3-18151-12	972998	Winkelverschr. 3/8NPT-12L	Angle connection 3/8NPT-12L	Raccord à vis coudé 3/8NPT-12L	Avvitamento angolare 3/8NPT-12L	1
08W7-73230-10	973002	Winkelverschr. 1/4NPT-10L	Angle connection 1/4NPT-10L	Raccord à vis coudé 1/4NPT-10L	Avvitamento angolare 1/4NPT-10L	1
09C1-MCKPK-06	964237	Ueberwurfmutter	Swivel nut	Ecrou de serrage	Dado a risvolto	2
09D1-02224-14	973011	Dichtring 1/4"	Sealing ring 1/4"	Joint d'étanchéité 1/4"	Anello di tenuta 1/4"	2
09S2-04488-06	973017	T-Schwenkverschr. 1/4 -06	T-Swivelling fitting 1/4-06	T-Raccord à vis orientable 1/4-06	Collegamento a vite orientabile T 1/4	1
13G5-14012-25	973618	Gummigriff Antriebe	Rubber grip drive	Poignée en caoutchouc	Impugnatura in gomma	2
13V1-13494-00	973637	Verschussdeckel 1 Zoll	Sealing Cap	Couvercle grand	Tappo serbaio grande	1
XXXKL-00000-10	968231	2 Kleber Panolin HLP UNI 37	2 adh. Panolin HLP UNI 37	Adhésive Panolin HLP UNI 37	2 adesivi Panolin HLP UNI 37	1
XXXKL-00000-11	964764	4 AU Klebbogen	4 AU adhesive sheet	4 AU Adhésive page	4 fogli con adesivi AU	1
XXXKL-00000-16	10979128	4 Kleber TY-HS Gr.2 silber	4 Sticker TY-HS Gr. 2 silver	4 Adhésive TY-HS Gr. 2 silver	4 adesivi TY-HS Gr. 2 argento	2

Druckübersetzung:

i Druck= 1/25

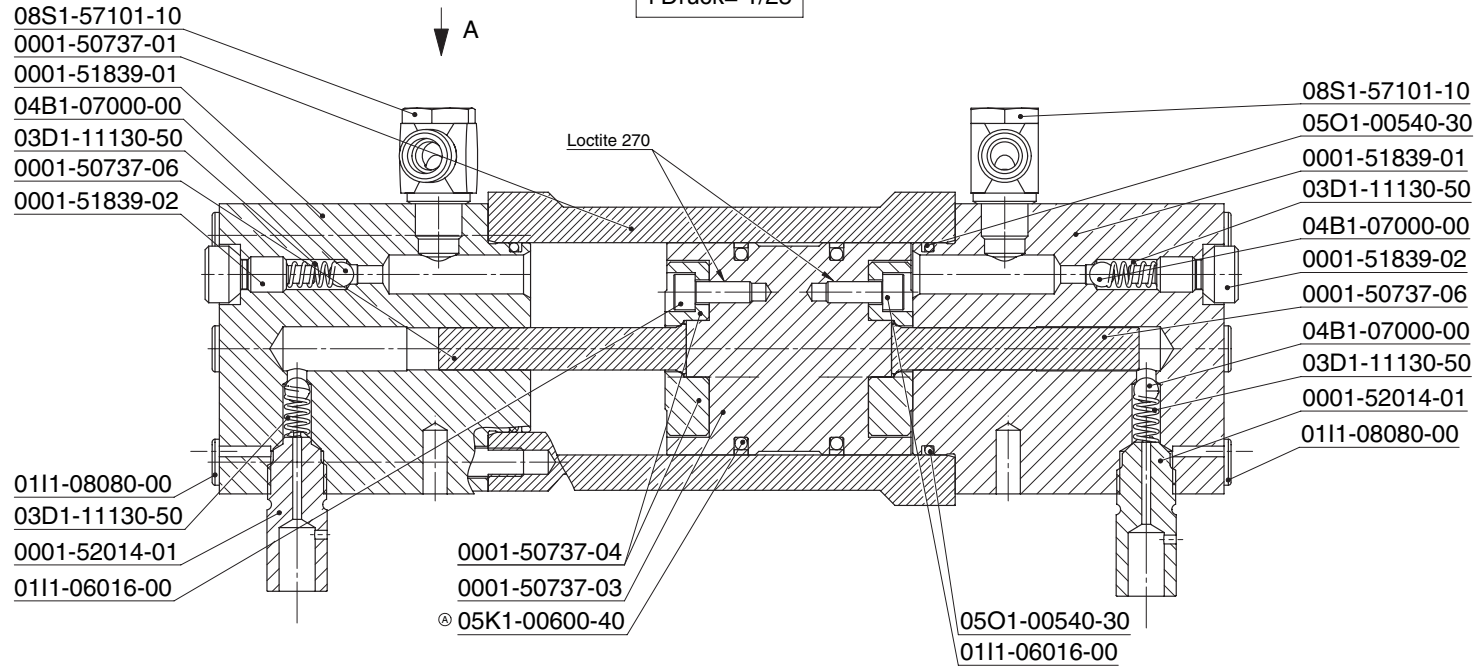

Ansicht A

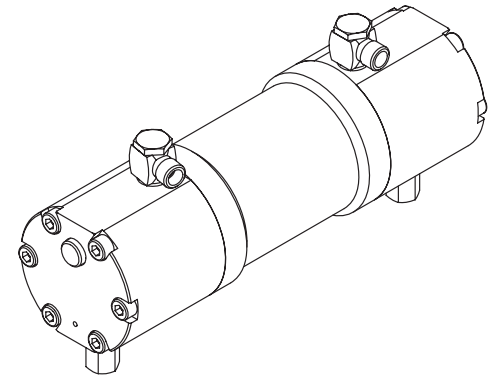
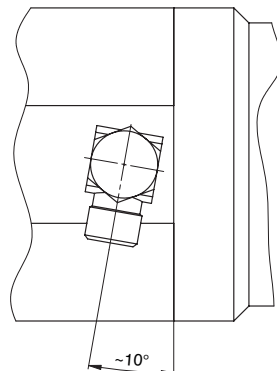

99HP-51089-01	974042	Booster kompl.	High pressure booster	Booster complet	Booster kompl.	1
Zeichn. Nr.	Mat. Nr.	Deutsch	English	Français	Italiano	Stk.
0001-50737-01	970281	Zylindermantel AU/AR	cylinder jacket AU/AR	Zylindermantel AU/AR	Zylindermantel AU/AR	1
0001-50737-03	970282	Boosterkolben AU/AR	Boosterpiston AU/AR	Boosterkolben AU/AR	Boosterkolben AU/AR	1
0001-50737-04	970283	Stößelhalter AU/AR	rod holder AU/AR	Stößelhalter AU/AR	Stößelhalter AU/AR	2
0001-50737-06	970267	Stößel AR/AU	rod AR/AU	Stößel AR/AU	Stößel AR/AU	1
0001-51839-01	970370	Boosterdeckel AU/AR/4B	Boostercover AU/AR/4B	Boosterdeckel AU/AR/4B	Boosterdeckel AU/AR/4B	1
0001-51839-02	970371	Dichtschaube AU/AR/4B	screw AU/AR/4B	Vis d'étanchéité AU/AR/4B	Dichtschaube AU/AR/4B	2
0001-52014-01	976246	HD-Boosternippel AU/AR/2A	HP-Booster nipple AU/AR/	HD-Boosternippel AU/AR/2A	HD-Boosternippel AU/AR/2A	2
0111-06016-00	971705	Inbus-Schraube M6x16	Socket screw M 6x 16	Vis CHC M6x16	Vite brugola M6X16	6
0111-08080-00	971752	Inbus-Schraube M8x80	Socket screw M 8x 80	Vis CHC M8x80	Vite brugola M8x80	12
03D1-11130-50	972068	Druckfeder Dm6,3/1,0x14,5	comp. spring dia 6,3/14,5	Druckfeder Dm6,3/1,0x14,5	Druckfeder Dm6,3/1,0x14,5	4
04B1-07000-00	972116	KUGEL Dm 7	Ball dia 7 mm	Kugel Dm 7	Kugel Dm 7 mm	4
05K1-00600-40	976270	Dichtung KDS 60 60%Bc	seal KDS 60 60%Bc	Dichtung KDS 60 60%Bc	Dichtung KDS 60 60%Bc	2
05O1-00540-30	972269	O-Ring 54.00x3.00 N 70	O-Ring 54.00x3.00 N 70	O-Ring 54.00x3.00 N 70	O-Ring 54x3 N 70 avanz.el	2
08S1-57101-10	972963	Schwenkverschr. 1/4-10 L	Swivelling Bolt fitting	Raccordo a vis coude 1/4-1	Raccordo "L" 1/4"-10L Fe	2

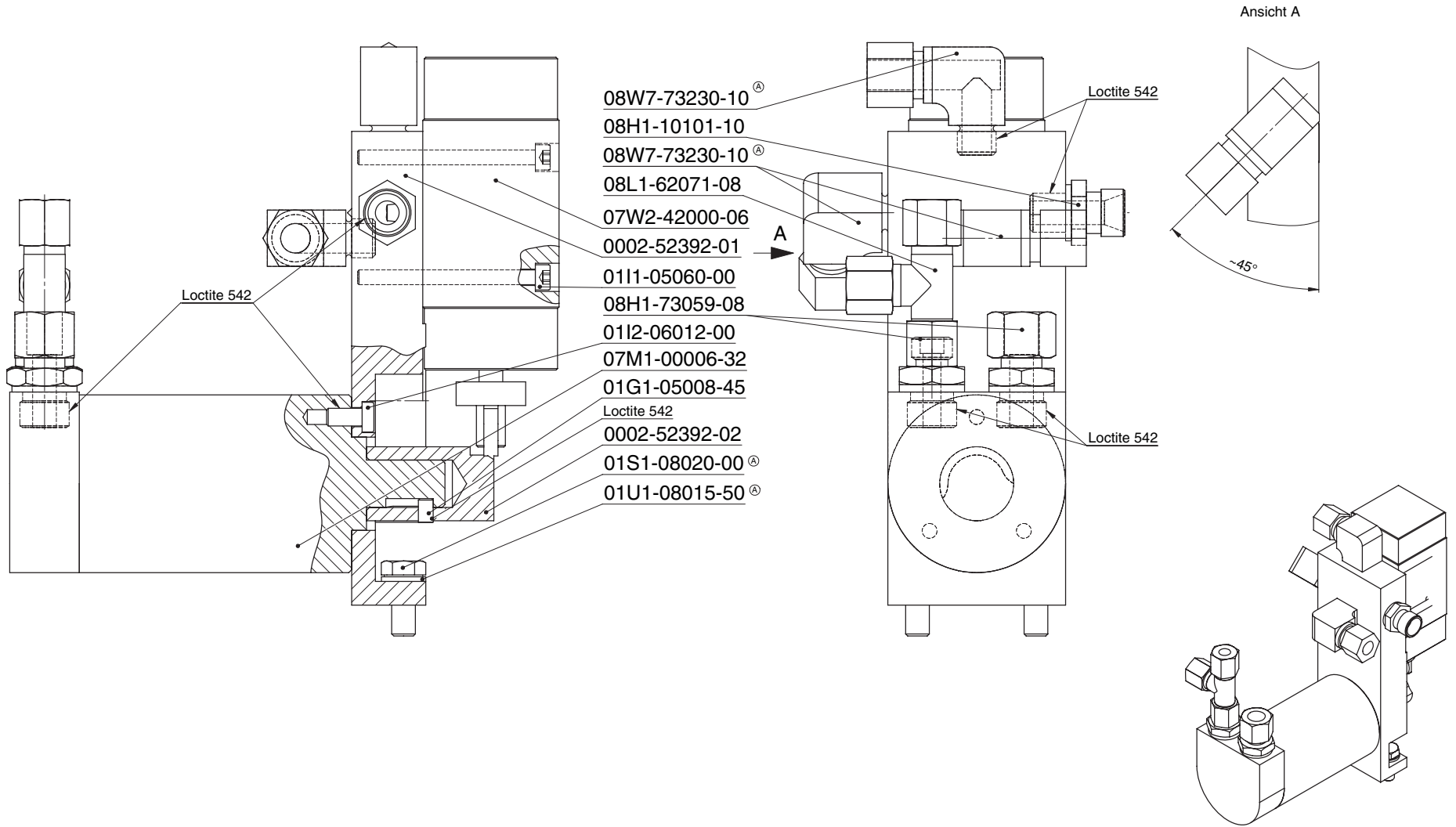

99HP-52394-00	974051	HD-Takter Danfoss	HP control unit	HD-Takter Danfoss	HD-Takter Danfoss	1
Zeichn. Nr.	Mat. Nr.	Deutsch	English	Français	Italiano	Stk.
0002-52392-01	971245	Takterflansch HD-Pumpen	cyclerflange HD-pump	Takterflansch HD-Pumpen	Takterflansch HD-Pumpen	1
0002-52392-02	971246	Kurvenzapfen HD-Pumpen	Cam pin HP-pump	Kurvenzapfen HD-Pumpen	Kurvenzapfen HD-Pumpen	1
01G1-05008-45	974826	Gewindestift M5x8	Set screw M5x8	Goujon M5x8	Grano M5X8	1
0111-05050-00	971699	Inbus-Schraube M5x50	Socket screw M 5x 50	Vis CHC M 5x 50	Vite brugola M5x50	4
0112-06012-00	971808	Inb-Schr.nied.Kopf M6x12	Allen head screw M 6x12	Vis 6pans tête cr. M6x12	Vite brugola M6X12 PRISMA	3
01S1-08020-00	971898	6kt-Schraube M8x20	hex.-screw M8x20	Vis 6 pans M8x20	Vite M8x20	2
01U1-08015-50	979353	U-Scheibe M8	washer M8	Rondelle M8	RondellaM8	2
07M1-00006-32	972579	Hydraulikmotor OMM 32	Hydraulic motor OMM 32	Moteur nu dunfos OMM32	MOTORE OMM 32	1
07W2-42000-06	972823	4/2-Wege-Takterventil AU	Directional control	DISTRIBUTEUR 4/2 AU	4/2-Wege-Takterventil AU	1
08H1-10101-10	972877	Ger.Verschr. 1/4-10L	Straight screw connec.	Ger.Verschr. 1/4-10L	Raccordo 1/4-10L	1
08H1-73059-08	972882	Ger.Verschr. 3/8-08L	Straight screw connection	Raccord droit 3/8"-08L	Ger.Verschr. 3/8-08L	2
08L1-62071-08	972905	L-Verschraubung Rohr 08 L	L-type connection	Raccord a vis en L Tube 8	Raccordo "T" 08L Fe-Fe-Ma	1
08W7-73230-10	973002	Winkelverschr. 1/4NPT-10L	Angled Screw Con.	Raccord coude 1/4NPT-10L	Winkelverschr. 1/4NPT-10L	3

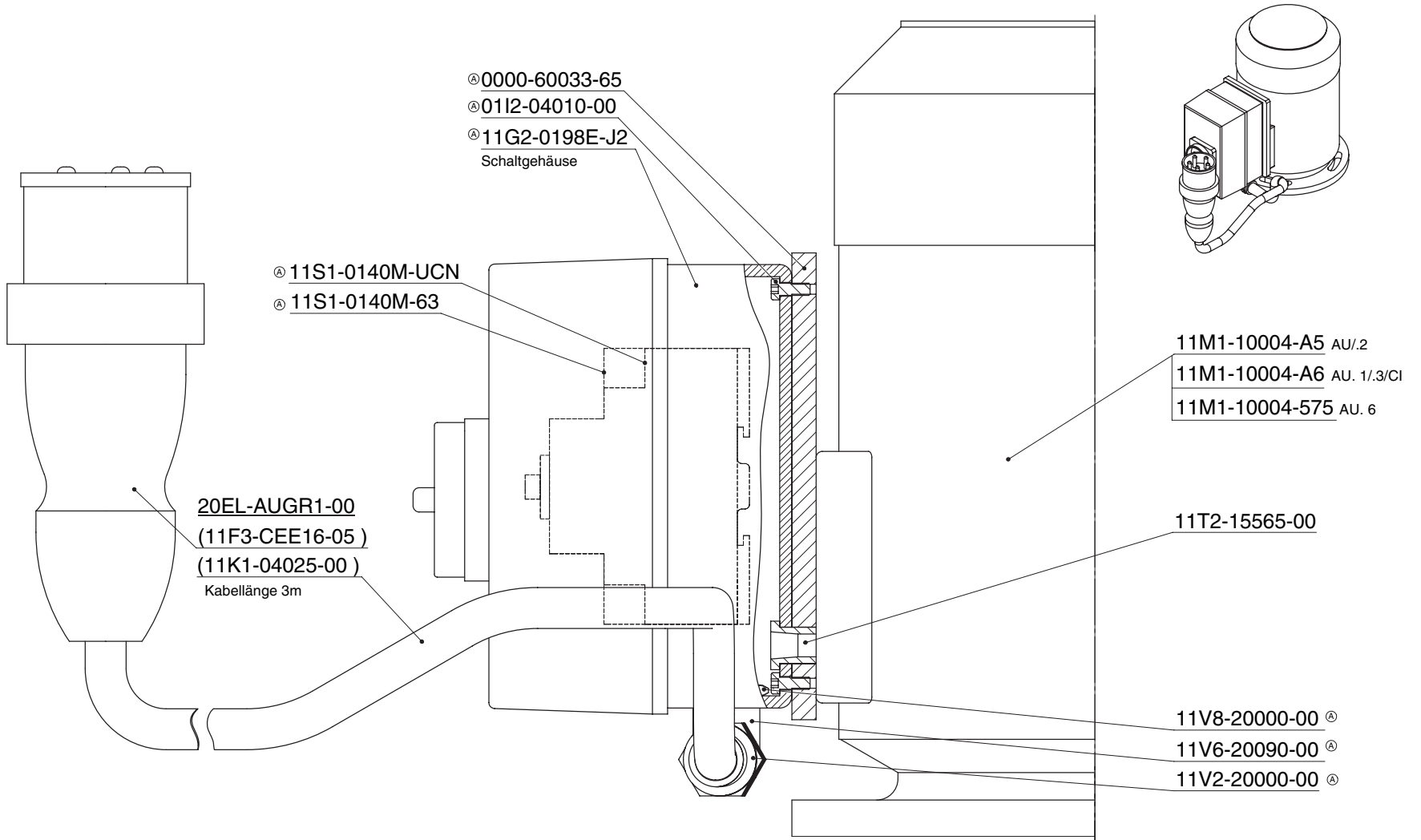

99MP-60078-20	980682	El.-Motor m. Anbau	El.-Motor with attachment	El.-Motor mit Anbau	El.-Motor mit Anbau	1
Zeichn. Nr.	Mat. Nr.	Deutsch	English	Français	Italiano	Stk.
0000-60033-65	10982448	Schalterplatte neu	Switch plate new	Schalterplatte neu	Schalterplatte neu	1
11M1-10004-A5	973128	Elektromotor 2,2kW (AU)	Electric motor	Moteur élec. 2,2kW (AU)	Elektromotor 2,2kW (AU)	1
25RS-38405-AU/N	10982452	Rüst. El.Steuer. AU neu	Conv.kit switchbox AUnew	Rüst. El.Steuer. AU neu	Rüst. El.Steuer. AU neu	1

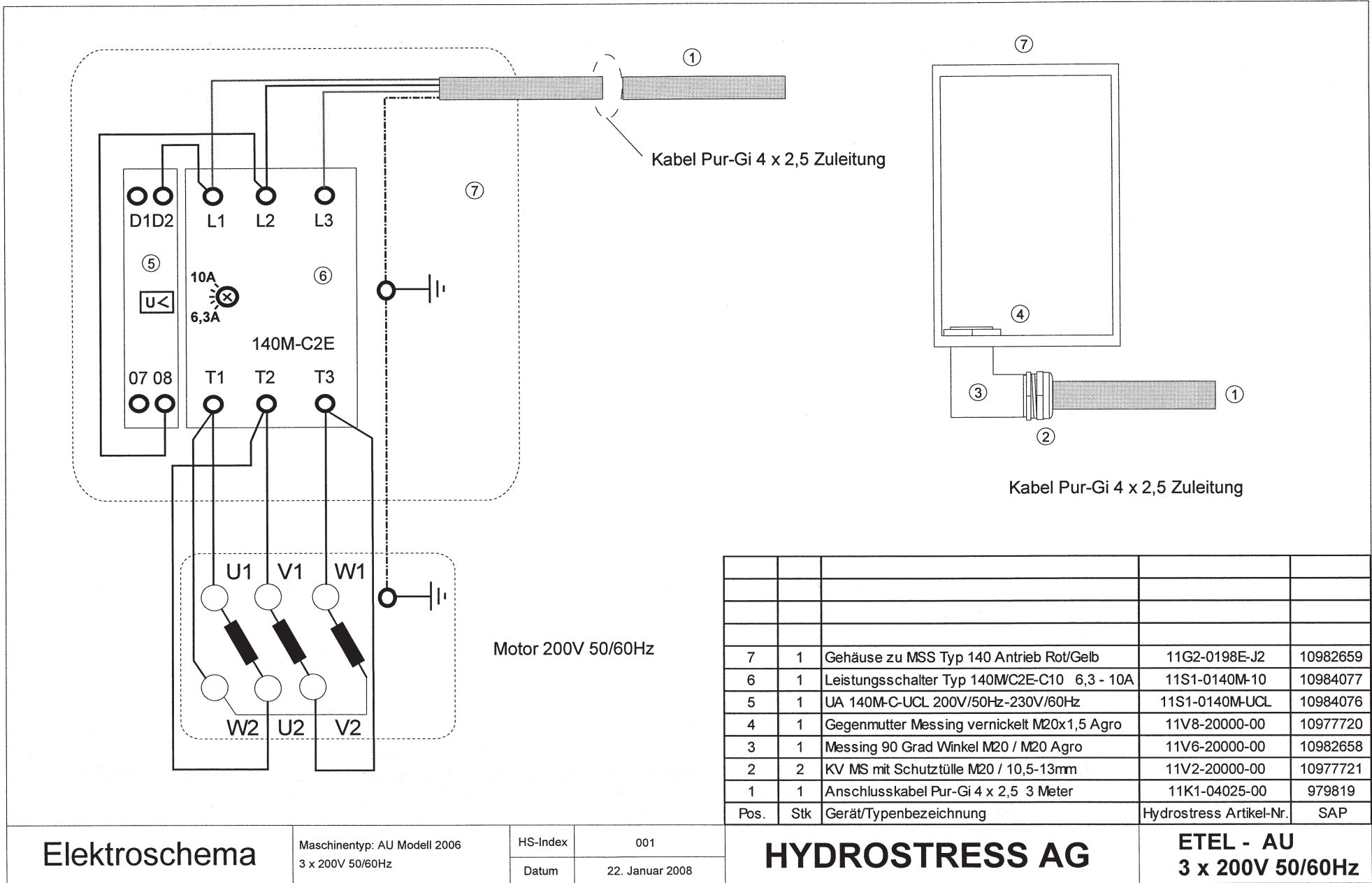

Pos.	Stk	Gerät/Typenbezeichnung	Hydrostress Artikel-Nr.	SAP
7	1	Gehäuse zu MSS Typ 140 Antrieb Rot/Gelb	11G2-0198E-J2	10982659
6	1	Leistungsschalter Typ 140WC2E-C10 6,3 - 10A	11S1-0140M-10	10984077
5	1	UA 140M-C-UCL 200V/50Hz-230V/60Hz	11S1-0140M-UCL	10984076
4	1	Gegenmutter Messing vernickelt M20x1,5 Agro	11V8-20000-00	10977720
3	1	Messing 90 Grad Winkel M20 / M20 Agro	11V6-20000-00	10982658
2	2	KV MS mit Schutztüle M20 / 10,5-13mm	11V2-20000-00	10977721
1	1	Anschlusskabel Pur-Gi 4 x 2,5 3 Meter	11K1-04025-00	979819

Elektroschema

Maschinentyp: AU Modell 2006
3 x 200V 50/60Hz

HS-Index

001

Datum

22. Januar 2008

HYDROSTRESS AG

ETEL - AU
3 x 200V 50/60Hz

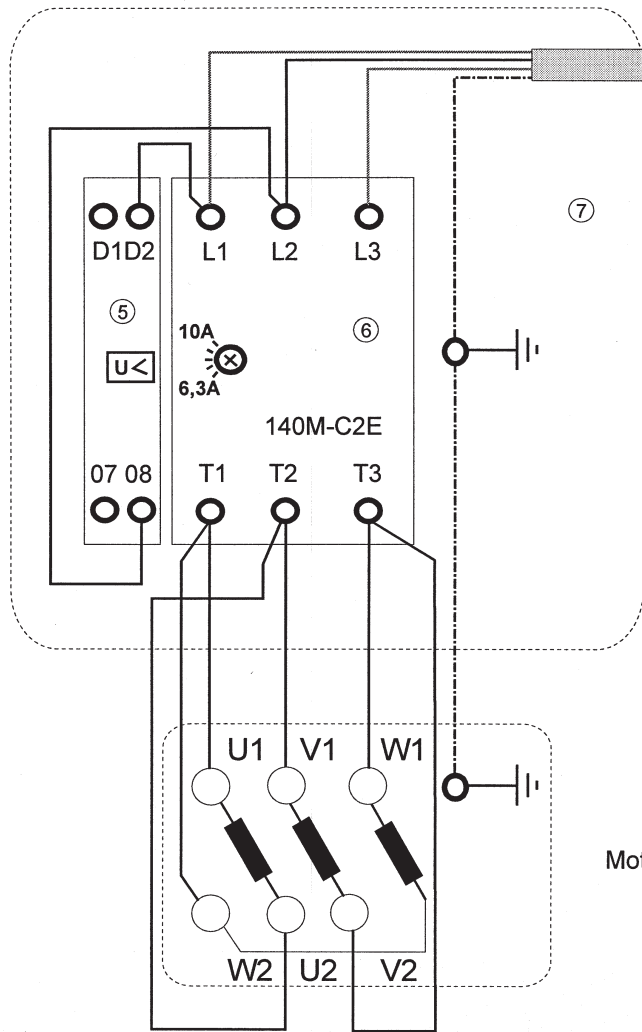

Kabel Pur-Gi 4 x 2,5 Zuleitung

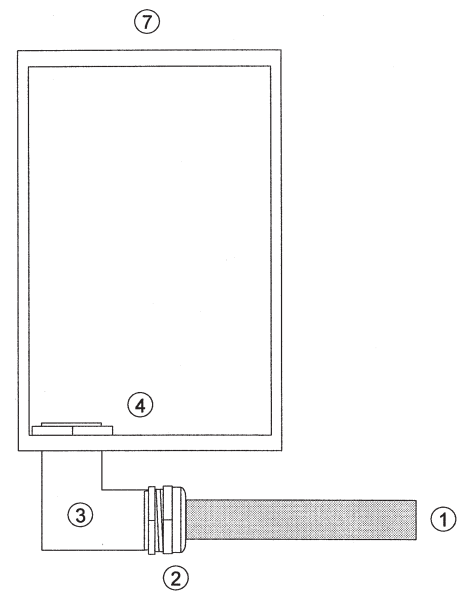

Kabel Pur-Gi 4 x 2,5 Zuleitung

Motor 230V / 50z

7	1	Gehäuse zu MSS Typ 140 Antrieb Rot/Gelb	11G2-0198E-J2	10982659
6	1	Leistungsschalter Typ 140WC2E-C10 6,3 - 10A	11S1-0140M-10	10984077
5	1	UA 140M-C-UCF 220-230V/50Hz	11S1-0140M-UCF	10984075
4	1	Gegenmutter Messing vernickelt M20x1,5 Agro	11V8-20000-00	10977720
3	1	Messing 90 Grad Winkel M20 / M20 Agro	11V6-20000-00	10982658
2	2	KV MS mit Schutzülle M20 / 10,5-13mm	11V2-20000-00	10977721
1	1	Anschlusskabel Pur-Gi 4 x 2,5 3 Meter	11K1-04025-00	979819
Pos.	Stk	Gerät/Typenbezeichnung	Hydrostress Artikel-Nr.	SAP

Elektroschema

Maschinentyp: AU Modell 2006
3 x 230V / 50Hz

HS-Index	001
Datum	22. Januar 2008

HYDROSTRESS AG

ETEL - AU.5
3 x 230V / 50Hz

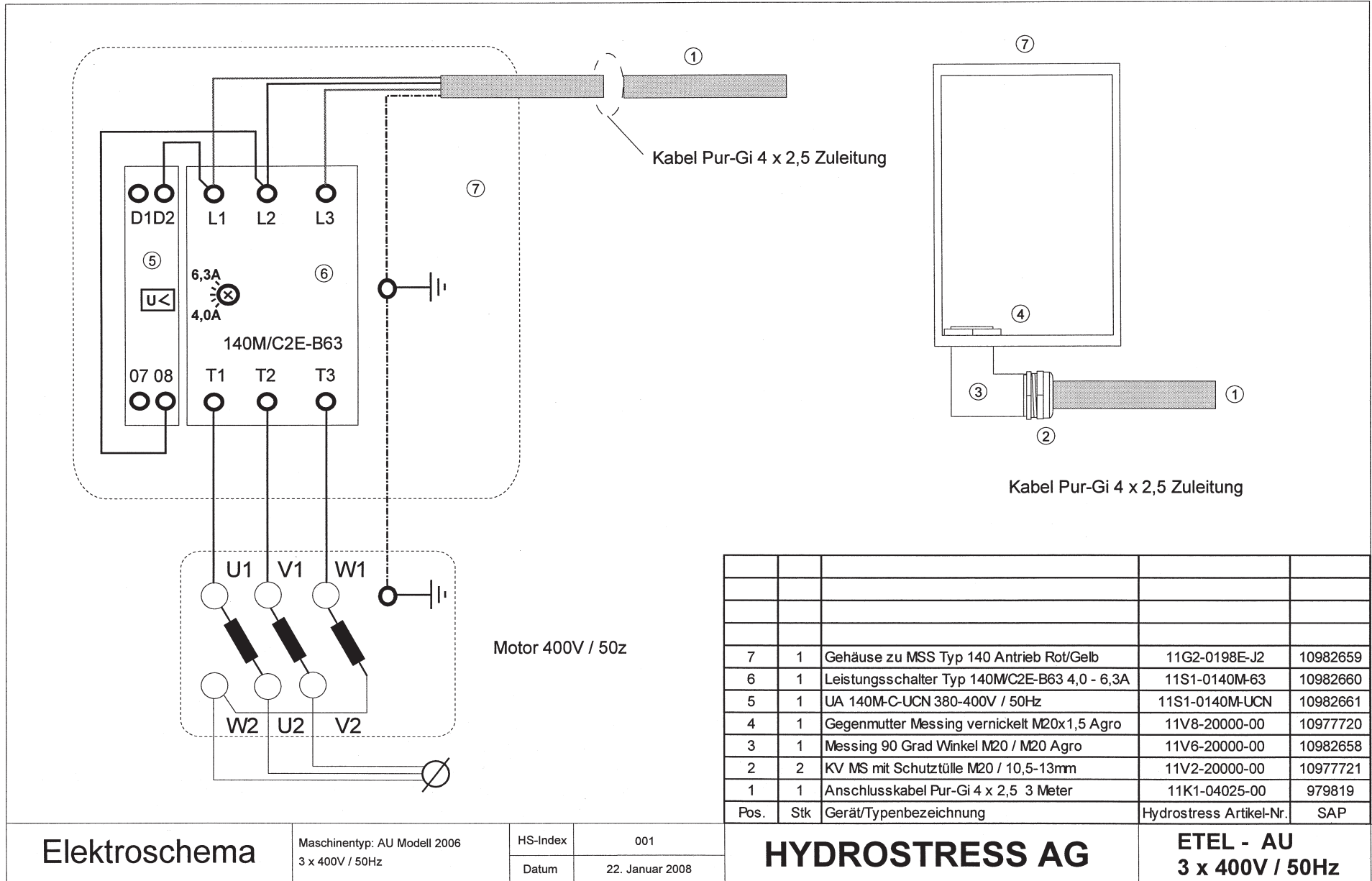

Elektroschema

Maschinentyp: AU Modell 2006
3 x 400V / 50Hz

HS-Index

001

Datum

22. Januar 2008

HYDROSTRESS AG

ETEL - AU
3 x 400V / 50Hz

